

SECTION A-A

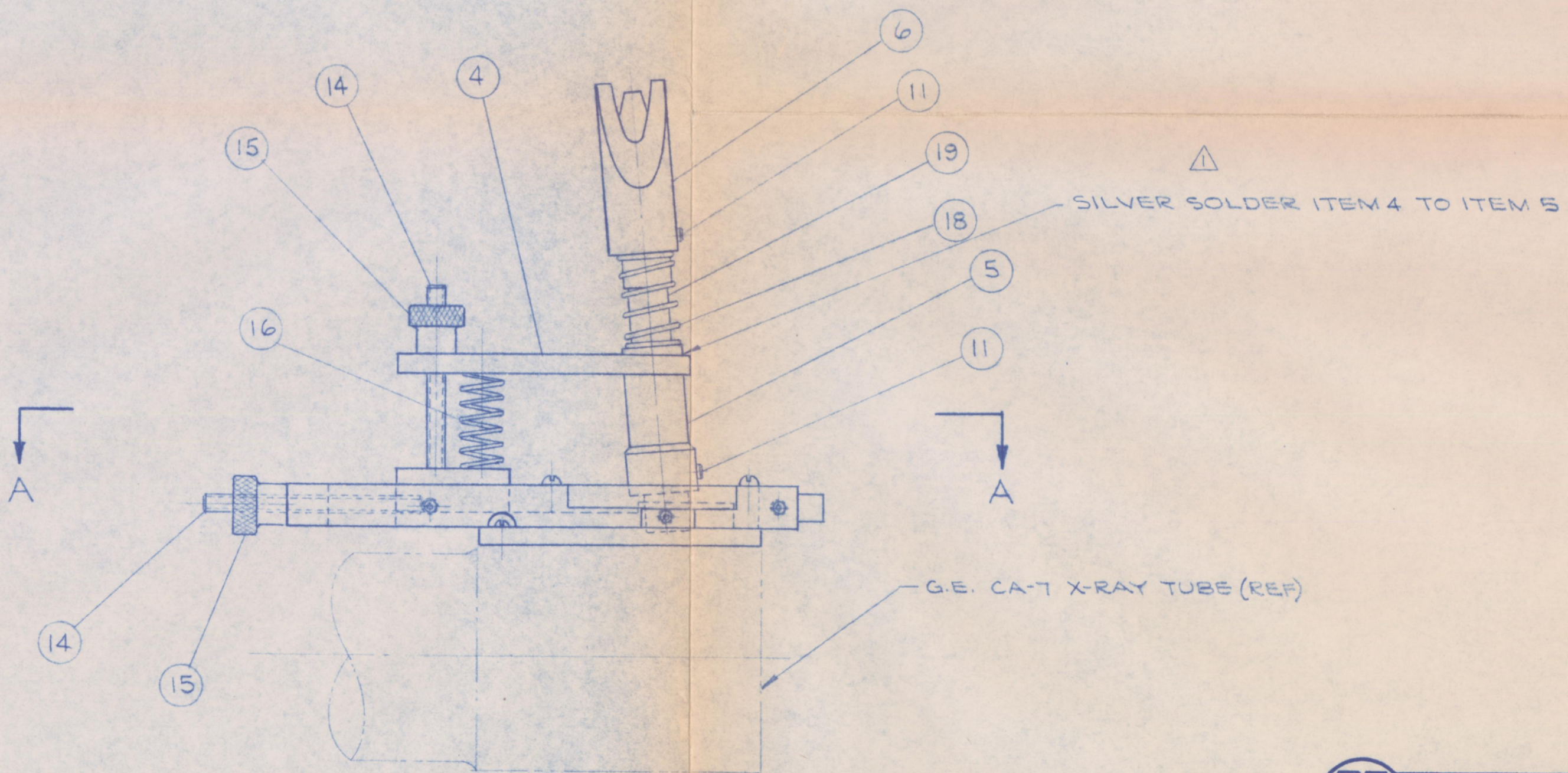

BILL OF MATERIAL B-1332

NEXT ASS'Y D-321



McCARTNEY MFG. CO.
BAXTER SPRINGS KANSAS

COLLIMATOR ASS'Y

UNLESS OTHERWISE SPECIFIED
TOLERANCE: FRACTIONS _____, DECIMALS _____
BREAK SHARP CORNERS AND EDGES _____ ALL OVER.
SURFACE FINISH _____ ALL OVER.

REV. 1	CHANGE NOTE	12-2-63	REF. No. 1
REV. 2			REF. No. 2
REV. 3			REF. No. 3

SCALE	FULL	DATE	7-27-63
MATL	HEAT TREAT	DWG.	LEP
	PART No.	APPRD.	
CATALOG No.		DWG. No.	C-538